

See discussions, stats, and author profiles for this publication at: <https://www.researchgate.net/publication/342105223>

CHARACTERISTICS OF TRADITIONAL TWO-STOREY RURAL HOUSES IN CENTRAL PART OF KOSOVO AND METOHIJA

Conference Paper in САВРЕМЕНА ТЕОРИЈА И ПРАКСА У ГРАДИТЕЉСТВУ · June 2020

DOI: 10.7251/STP2014207N

CITATIONS

0

READS

219

1 author:



Nenad Nikolić

Faculty of Technical Sciences - University of Pristina in Kosovska Mitrovica

3 PUBLICATIONS 2 CITATIONS

SEE PROFILE



**СТЕП
ГРАД**

Међународна конференција
Савремена теорија и пракса у градитељству XIV

International Conference on Contemporary Theory and Practice in Construction XIV **STEPGRAD**

ЗБОРНИК РАДОВА PROCEEDINGS

stepgrad.aggf.unibl.org

11-12.06.2020.



**МЕЂУНАРОДНА КОНФЕРЕНЦИЈА
САВРЕМЕНА ТЕОРИЈА И ПРАКСА У ГРАДИТЕЉСТВУ XIV**

INTERNATIONAL CONFERENCE ON CONTEMPORARY
THEORY AND PRACTICE IN CONSTRUCTION XIV

**ЗБОРНИК РАДОВА
PROCEEDINGS**

Издавач Универзитет у Бањој Луци
Publisher Архитектонско-грађевинско-геодетски факултет

University of Banja Luka
Faculty of Architecture, Civil Engineering and Geodesy
За издавача др Бранкица Милојевић, ванр. професор
On behalf of publisher Brankica Milojević, PhD, associate professor

Уредници др Александар Борковић, ванр. професор
Editors Aleksandar Borković, PhD, associate professor

др Мирослав Малиновић, доцент
Miroslav Malinović, PhD, assistant professor

**ЕЛЕКТРОНСКО ИЗДАЊЕ –
ДИСТРИБУЦИЈА ПУТЕМ ИНТЕРНЕТ СТРАНИЦЕ
КОНФЕРЕНЦИЈЕ:
stepgrad.aggf.unibl.org
и
doisrpska.nub.rs/index.php/STPG/index**

DIGITAL PUBLICATION – DISTRIBUTION THROUGH
CONFERENCE WEB SITE:
stepgrad.aggf.unibl.org
and
doisrpska.nub.rs/index.php/STPG/index

Бања Лука, 2020.
Banja Luka, 2020

ISSN 2566-4484



Nenad J. Nikolić, nenad.nikolic@pr.ac.rs, Faculty of Technical Sciences, Department of Architecture, University of Priština in Kosovska Mitrovica

CHARACTERISTICS OF TRADITIONAL TWO-STOREY RURAL HOUSES IN CENTRAL PART OF KOSOVO AND METOHİJA

Abstract:

This paper deals with the analysis of development and the features of traditional two-story rural houses built in central part of Kosovo and Metohija between the First and the Second World War. The study based on in-situ explorations and literature review has revealed the values of these traditional examples in terms of spatial organization, architectural style, principles of construction, and sustainability-related characteristics. In particular, the study has been deepened on the case of the house of Petković family in Laplje Selo, thus acknowledging the details of this residential type.

Keywords: traditional house, Kosovo and Metohija, principles of design and construction

КАРАКТЕРИСТИКЕ ТРАДИЦИОНАЛНИХ ДВОСПРАТНИХ СЕОСКИХ КУЋА НА ЦЕНТРАЛНОМ КОСОВУ И МЕТОХИЈИ

Сажетак:

Овај рад се бави анализом развоја и карактеристика традиционалних двоспратних сеоских кућа које су изграђене на централном Косову и Метохији између Првог и Другог светског рата. Истраживање, спроведено обиласком локалитета и прегледом литературе, открило је вредности ових традиционалних примера у смислу просторне организације, архитектонског стила, градитељских принципа и одрживих карактеристика. Затим, истраживање је детаљније спроведено кроз анализу студије случаја куће породице Петковић у Лапљем Селу, разоткривајући детаље овог стамбеног типа.

Кључне ријечи: традиционална архитектура, Косово и Метохија, градитељски принципи

1. INTRODUCTION

The area of Kosovo and Metohija is characterized by geographical and cultural diversity. Central part of this territory, known as the Field of Kosovo, features sunny yet windy fertile plateau with emphasized seasonal variations in temperature and precipitation. Thanks to its natural advantages, position in relation to other regions and the connectivity, this territory has been populated since ancient times. In the modern age, both urban and rural settlements have been developing in central Kosovo and Metohija. Sharp spatial differentiation between the “urban” and the “rural” at the very end of the 20th and the beginning of the 21st century, representing an outcome of the overall social transformation, impacted the formation of Gračanica rural zone next to the urban core of the city of Priština. Due to intensive expansion of urban territory and urban functions happening continuously over the last two decades, adjacent rural settlements inevitably became subjected to the transition and its consequences [1] Ongoing pressure of “urban” on “rural” weakens the bond with tradition and shifts the relation towards its most prominent material expression that is the traditional residential architecture.

Although in recent years a lot of effort has been invested to protect major architectural heritage in Kosovo and Metohija, such as churches and monastery complexes, little attention has been paid to traditional rural houses. For that reason, traditional rural house from Kosovo and Metohija nowadays represents a jeopardized yet valuable [2] form of material heritage. In fact, traditional rural houses best illustrate a diversity of living cultures and practices, building methods, and architectural styles. Recording and research of traditional rural houses represent an objective need, in particular in less studied territories [3].

The Field of Kosovo is valuable agrarian landscape and traditional architecture is its significant component. Though a great part of traditional built stock has already disappeared, the objects that still exist put central part of Kosovo and Metohija among areas that are attractive to tourists, researchers and architectural practitioners [4]. Rural settlements in the Field of Kosovo were developed at micro locations that were suitable for productive (agricultural) activities [5], often near rivers (such as Gračanka or Sinica) or river streams. Relatively flat terrain on this territory as well as the mixing of local and distanced building practices allowed for the development of different types traditional single-family houses.

The development of residential architecture in this area, especially the spatial component, was influenced by powerful political, economic and cultural factors. Therefore, traditional houses in central Kosovo and Metohija show greater variability in spatial dimensions than in construction methods [6].

The houses built during the 19th and the early 20th century are mostly single-story and simple in concept and construction. There is nothing superfluous about them, nothing that has no purpose. Limited economic opportunities did not allow for dispersion, in either material or space. These modest opportunities also led farmers to alone build their houses, in most cases. The result of such construction tradition was a full-range simplicity of the built structure, which is of great practical importance [2]. Following the end of the First World War, nevertheless, the construction of two-storey houses in this area has been intensified.

2. TRADITIONAL TWO-STOREY HOUSES IN CENTRAL KOSOVO AND METOHIJA

Architecture is conditioned by the following three major components: building materials, climatic conditions and people’s lifestyles [7]. A farmhouse in Serbia at the beginning of the 20th century shows remarkable progress [8]. The importance of the house as a space within rural life is the same in all parts of our country. The most important element of the house is the hearth, which becomes the center of formation of the entire living organization of a villager. By the function of space we can recognize: food preparation, living room, laundry, food storage, and sleeping. Considering that all these numerous functions are organized in a small and reduced space, then the folk builder must be honored for the rational and inventive management and solving skills [9].

Both the single- and the two-story house from central Kosovo and Metohija feature elongated rectangular base. If the house is single story, the cattle barn is either built separately or occupies one department within the house itself. In the two-story houses the barn is located on the ground floor. Neither one-story nor two-story houses have basement.

In the internal organization of the space, the connection between the rooms was made only through the porch; the direct connection between the rooms is very rare and was an exception [2]. The kitchen, or food preparation room, is entered from the porch on the ground floor, and is additionally illuminated by a single windows on the side, in which, besides several niche in the walls for storage of kitchen items, there is a large hearth in the wall on the right side. In addition to this room there are other rooms. There was a wooden staircase on the ground floor porch leading upstairs. Upstairs there is a gallery that follows the length of the house, above the porch on the ground floor, from where one can enter several rooms, usually the same size, used for sleeping, with two gallery oriented windows in each room. The interfloor structure, as well as the roof structure, are made of lumber, while the flooring on the ground floor is made of compacted soil. The houses are built and supplied by the villagers themselves, assisting one another in the work. The lumber grain was brought from nearby forests, the stone was removed from the Maidan and the bricks were made of soil and baked in the sun. The mortar was also made from the soil by local builders, mixing it with sawdust, while the lime was dissolved at the construction site itself. A large number of houses are left unpainted on the outside, although at one time it was required to paint them white, while in the interior they were mostly unpainted [10].



Figure 1. Photographs of two-storey family houses in central Kosovo and Metohija. a) Popović family house in Gračanica; b) Marković family house in Gračanica; c) Nikolić family house in Gračanica; d) Čurčić family house Dobrotn; e) Miljković family house in Livadje; f) Maksimović family house in Dobrotn

Like the ground floor houses, two-story houses in the vicinity of Priština were covered “*ćeramida*“ (ceramic roof tile) and have small and narrow windows, often two placed close to each other. The lateral, gable walls are thick and are usually made of broken stone, while the other walls are made of brick. At approximately meter of height, wooden beams are inserted into the wall, which are used for tightening and leveling the layers, functioning as ring beam nowadays. The roof sometimes contains an eyebrow dormer, so called “*badža*“, to illuminate the attic, and a chimney, so called “*odžak*“, to let smoke out of the furnace. The chimney is rectangular in shape in its base, covered with “*ćeramida*“ typical of Kosmet, which occurs in the area in the same shape [10].

After the World War I, with increased communication, more frequent migration and, consequently, greater outer influence, the transfer of architectural skills among different parts of Kosovo and Metohija intensified, and beyond, among the different parts of the Balkans. Sometimes, home builders would incorporate their experience from foreign countries, and as a result, for example, some of the two-story houses can even rightly be called palaces [11]. That is why the architectural expression of the two-story houses of central Kosovo and Metohija, although very valuable, is not exclusive to this area, and we find similar form in other parts of Kosmet (for example in the Parish of Sirinic) and in other parts of the Balkans.

The most significant sustainability-related qualities of traditional houses throughout all Kosovo and Metohija and the continental part of the southern Balkans are related to the materials and methods by which these materials are incorporated into the structure [11], [3]. It is hard to determine what a two-story single family home originally looked like in central Kosovo and Metohija, since no houses were preserved in their original condition. All older buildings in this area were modified with various repairs and alterations, and old equipment and hearths were removed [12].

These houses were built from traditional building materials that could be found or produced using resources in the immediate surroundings. Stone, mud, and wood were used to build the structural system: massive stone foundations, walls made of unbaked brick made of mud, so-called "čerpič", and wood for roof construction and to construct system that supported the precise thinning and stiffening of massive walls to prevent possible demolition. The massive masonry system used was a 50-70 cm thick wall of unbaked mud bricks as a guide material and binder. This construction system has proven to be a very durable structure, and by using natural materials we can conclude that in this way the house is best suited to the climate change conditions during the year. In time houses were developing, becoming bigger, but have always kept its formal simplicity forming regional traditional architecture.

Flexibility and use of natural materials during construction, the use of local, natural, non-toxic and biodegradable materials ensures comfort and quality of life throughout the life cycle of the building. This construction principle is environmentally correct both in the construction phase and in the life span of the building and in the post-construction phase where the structural waste of the entire building is minimized.

Table 1. Sustainable – "green" features of building materials of Kosovo Field traditional house (criteria based on [13])

Building Phase	Criteria	Building material				
		Stone	Wood	Clay tiles	Lime plaster	Glass
Pre-building phase: Manufacture	Local material	+	+	+	+	
	Natural material	+	+	+	+	+
	Recycle content				+	
Building phase: Use	Energy efficient					
	Non-toxic	+	+	+	+	+
	Durability	+				
Post-building phase: Disposal	Reusability	+	+	+		
	Recyclability		+	+		+
	Biodegradability		+	+	+	

3. CASE STUDY: PETKOVIĆ FAMILY HOUSE IN LAPLJE SELO

Pristina and its surroundings were predominantly inhabited by Serbs in the period between the two World Wars, therefore this house in Laplje Selo was inhabited by Serbs as well. Its gauge is 11 m length and 7 m width. The house is two-story, with a gallery on the longer side, both on the ground floor and upstairs. The organizational chart of the house indicates a clear division into the day and night zones, which is a general characteristic of the traditional examples, as well as their connection through a semi-open gallery area. The ground floor is in line with the surrounding ground, which creates a direct functional and visual connection between the outer and inner spaces. From the ground floor porch one can enter two separate rooms that are not directly interconnected.

The Petkovic family house is a unique example of two-story houses built during this period where a cattle barn was separated from the house and built in another part of the yard. Two rooms on the ground floor of the Petrovic house don't have the same dimensions and the larger room was used as a living room, for preparing and serving food. This is why this room has additional windows on the east side, aimed to provide natural light in the early morning hours when during this time people were going to a field, church, or preparing for other activities or duties. During summer days in particular, the outside area becomes an extension of the house space, and vice versa. On the right side of the porch is a wooden staircase, only 90 cm narrow, leading upstairs. The stairs have a 70 cm high wooden fence. The upstairs gallery has a view over the courtyard. Two rooms of equal

dimensions are located upstairs, and have openings to the gallery and contribute to the formation of the front facade appearance. Front facade is optimally oriented to the south and all rooms have natural lighting, which is why maximum insolation is possible during winter days. 1.6 m wide porch plays a significant role in preventing direct sunlight from entering the rooms on summer days.

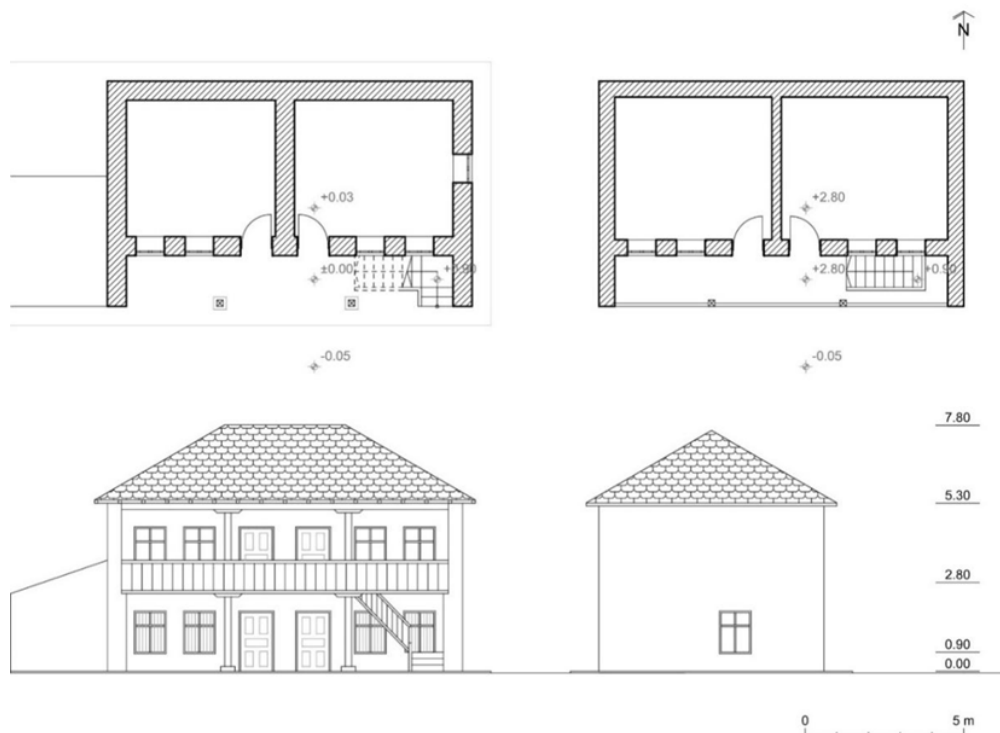

Figure 2. Floor plan and elevations of Petković family house in Laplje Selo

By analyzing the materials used during the construction of the family home of the Petković family in Laplje Selo, we can conclude that only local and natural materials that can be found in the immediate area were used. The foundation of the house was built with stone blocks and wooden beams placed above, which represents the structural material that stiffens the construction of the massive walls, which in this case are made of mud blocks. A layer of mud was then applied as a final layer, and then coated with limestone. The floor, interfloor and roof construction is made out of wood. The only material that is not obtained directly from natural materials, and requires additional factory processing is glass, while joinery is completely made of wood.

Wood was used to perform the structural system, straw and fiber was used as a binder and the mortar that was used could be characterized as a new source.



Figure 3. Photograph of used materials during construction of Petković family house in Laplje Selo

A massive construction system of unbaked bricks made of mud was used during construction and straw was used as a binder. A 60 cm thick unbaked brick wall rests on 60-80 cm stone foundations, while a 50 cm wall rests on it. The structure that holds the massive walls stiff and prevents them from collapsing is made of wood and extends over the entire length of the wall every 70-80 cm. These beams, in addition to stiffening and constructively supporting the walls, also play a role in the proper leveling of the bricks. The specificity of the construction of structures is reflected in the way the floor was constructed, the interfloor structure and the ceiling structure. Details of floor, interfloor and ceiling structures are shown in Figure 4.

The roof was originally covered by “*ćeramida*”. The porch downstairs and gallery upstairs is carried on three columns. The walls are made of unbaked brick „*ćerpič*“ and on the ground floor their thickness is 60 cm, while upstairs they are slightly thinner. The interfloor, roof, porch, gallery, staircase and the construction inside the walls are of lumber grain. The floor on the ground floor is of compacted soil and has been boarded in a later period. The walls were also plastered in a later period.

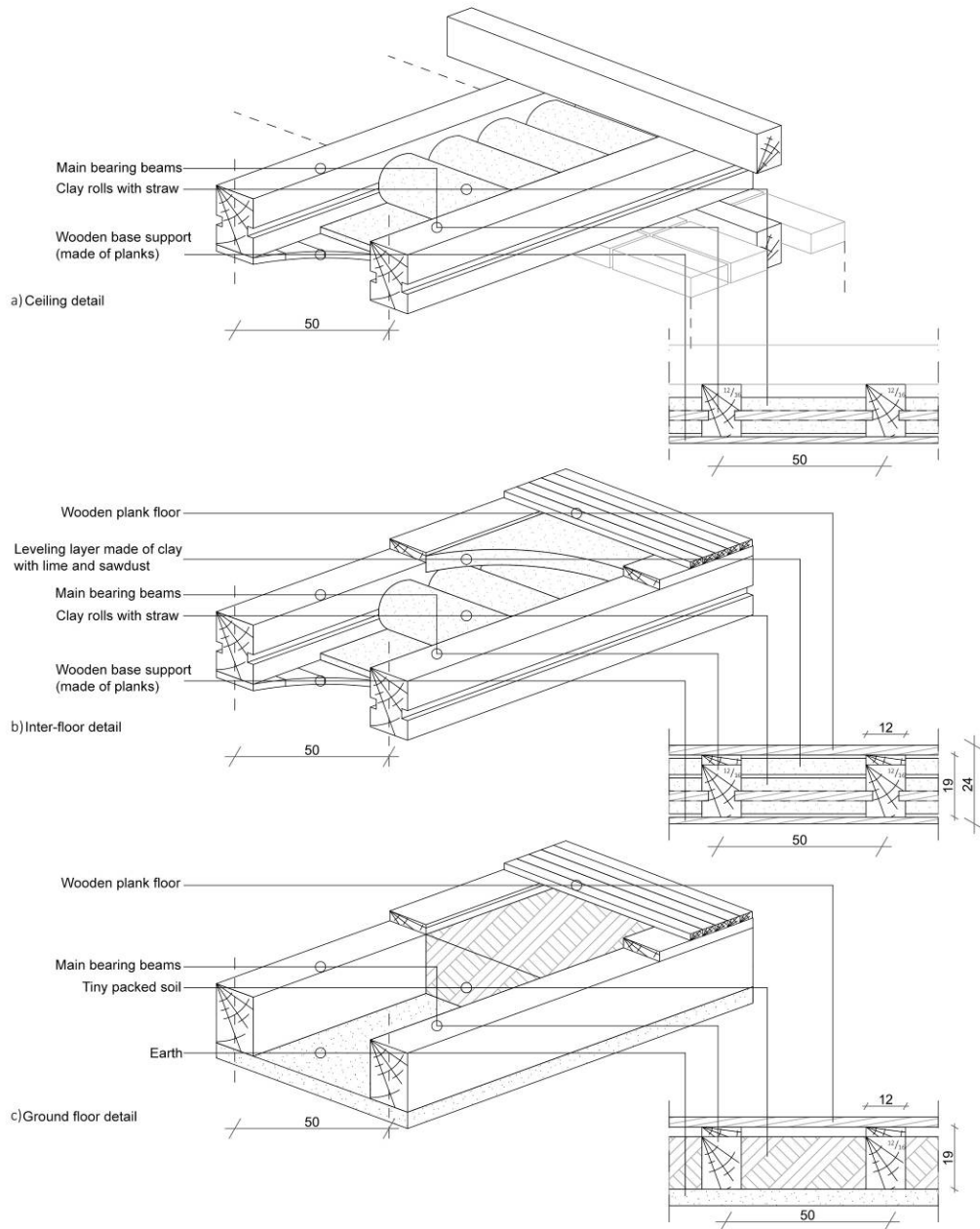

Figure 4. Construction details of Petrović family house in Laplje Selo, a) ceiling detail, b) interfloor detail and c) ground floor detail



Figure 5. Photographs of Petković's family house in Laplje Selo

4. CONCLUSION

This paper dealt with the analysis of traditional two-story houses built in central part of Kosovo and Metohija in the period between the First and the Second World War. Two-story houses represent the most advanced type of traditional residential architecture in this territory, having regarded that the formation of modern residential typology has been initiated right after the Second World War. Post-war houses demonstrate a sharp interruption of functional, formal and ecological traditions.

The research has shown that traditional two-story houses in central Kosovo and Metohija possess significant values based on which they deserve to be recognized and treated as material cultural heritage. In the first instance, the treatment should encompass protection of their existing architectural and sustainability-related values.

Next to that, the regeneration of traditional two-story single-family houses from Kosovo and Metohija would also refer to their functional reactivation. Bearing in mind that the number of remaining houses of this type is not large, as opposed to their values, a possible regeneration direction could refer to assigning a function of greater public significance to these structures. This means that the regenerated traditional houses from Kosovo and Metohija could become tourist accommodation i.e. additional elements (dependence unit of hotel), educational spots or the museums that witness the cultural wealth of this part of Balkans.

LITERATURE

- [1] S. Kosanović, A. Fikfak and S. G. Popović. (2016, June). "AGRARIAN LANDSCAPE BETWEEN TRANSITION AND SUSTAINABILITY - GRACANICA AREA CASE STUDY", *The Journal "Agriculture and Forestry"*, 62(2), pp. 227-241. Available: [10.17707/agricultforest.62.2.20](https://doi.org/10.17707/agricultforest.62.2.20) [23 February 2020].
- [2] R. Findrik, "Seoska kuća u Kosovu Polju" in *Zbornik zaštite spomenika kulture, 1957*, pp. 35-50.
- [3] S. Kosanović, B. Folić, S. Kovačević, I. Nikolić and Lj. Folić. (2019, Aug.). "A Study on the Sustainability of the Traditional Sirinić House in the Šar Mountain Region, the South-Western Balkans", *Sustainability*. [On-line]. 11(17), pp. 4711. Available: <http://dx.doi.org/10.3390/su11174711> [23 February 2020].
- [4] D. Ćukić, *Kosovo, znamenitosti i lepote*. Priština: Turistički savez Kosova, 1971.
- [5] N. Gadžić. (2016,). "Seoska arhitektura Sirinićke župe". *Patrimonium.MK*. [On-line]. 9(14), pp. 325-334. Available: [728.6\(497.751\)](https://doi.org/10.728.6(497.751)) [23 February 2020].
- [6] B. Kojić. *Seoska arhitektura i rurizam*. Beograd: Građevinska knjiga, 1958.
- [7] A. Deroko, "Stara varoška kuća u Srbiji, Kosmetu i Makedoniji, u poređenju sa kućom u Solunu, Carigradu i Maloj Aziji" in *Glasnik Etnografskog instituta Srpske akademije nauka, 1954*, pp. 407-417.
- [8] Z. Radić, "Pregled osnovnih tipova i načina gradnje seoskih kuća u Srbiji tokom XVIII i XIX veka" in *Glasnik Etnografskog muzeja, 1995*, pp. 58-59.
- [9] Z. Petrović, "Seoska „kuća“ i ognjišta na Kosovu i Metohiji" in *Glasnik Muzeja Kosova i Metohije, 1964*, pp. 369-373.
- [10] I. Zdravković, "Seoska kuća u okolini Prištine" in *Glasnik Etnografskog instituta Srpske akademije nauka, 1954*, pp. 793-803.
- [11] N. Gadžić. "Arhitektura Šar planinskih sela sa posebnim osvrtom na stvaralaštvo sredačkih zidara". Ph.D. thesis, Univerzitet u Beogradu, Srbija, 2016.
- [12] R. Findrik, "O prostoru stare seoske kuće" in *Saopštenja Republičkog zavoda za zaštitu spomenika kulture, 1982*, pp. 143-162.
- [13] R. Tomovska and A. Radivojević. (2017, Mar.). "Tracing sustainable design strategies in the example of the traditional Ohrid house", *Journal of Cleaner Production*. [On-line] 147, pp. 10-24. Available: <https://doi.org/10.1016/j.jclepro.2017.01.073> [23 February 2020].